



(86) 1999/07/21

(87) 2000/02/17

(72) TALLARIDA, STEVEN J., US

(72) ETTLINGER, MARK, US

(71) ANGIOLINK CORPORATION, US

(51) Int.Cl.⁷ A61B 17/04

(30) 1998/07/22 (60/093,701) US

(54) CANULE D'ASPIRATION VASCULAIRE, DILATATEUR ET
AGRAFEUSE CHIRURGICALE

(54) VASCULAR SUCTION CANNULA, DILATOR AND SURGICAL
STAPLER

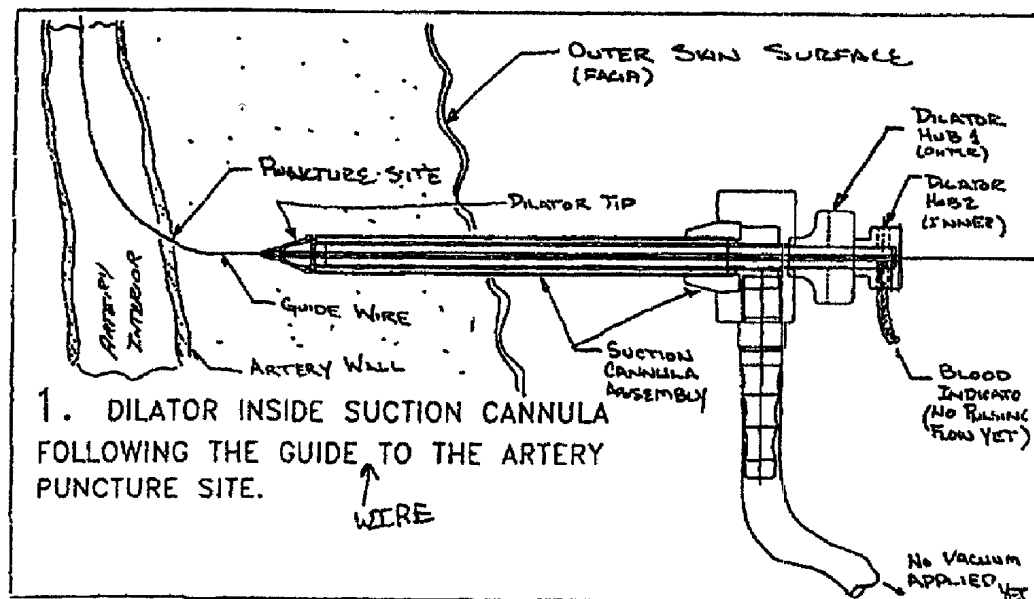

(57) A suction cannula (10), dilator (40), stapler (80) and staple (70) are provided herein. The stapler (80) is constructed to slide into the suction cannula (10) to approach a puncture in an artery, and to permit stapling of the artery.

PCT

WORLD INTELLECTUAL PROPERTY ORGANIZATION
International Bureau

INTERNATIONAL APPLICATION PUBLISHED UNDER THE PATENT COOPERATION TREATY (PCT)

(51) International Patent Classification ⁷ : A61B 17/04	A3	(11) International Publication Number: WO 00/07640 (43) International Publication Date: 17 February 2000 (17.02.00)
<p>(21) International Application Number: PCT/US99/16476</p> <p>(22) International Filing Date: 21 July 1999 (21.07.99)</p> <p>(30) Priority Data: 60/093,701 22 July 1998 (22.07.98) US</p> <p>(71) Applicant (for all designated States except US): STD MANUFACTURING, INC. [US/US]; 1063 Turnpike Street, Box 420, Stoughton, MA 02072 (US).</p> <p>(72) Inventors; and (75) Inventors/Applicants (for US only): TALLARIDA, Steven, J. [-/US]; 11 Victoria Lane, Mansfield, MA 02048 (US). ETTLINGER, Mark [US/US]; 546 Lowell Street, Lexington, MA 02420 (US).</p> <p>(74) Agent: SOLOWAY, Norman, P.; Hayes, Soloway, Hennessey, Grossman & Hage, 175 Canal Street, Manchester, NH 03101 (US).</p>	<p>(81) Designated States: AE, AL, AM, AT, AU, AZ, BA, BB, BG, BR, BY, CA, CH, CN, CU, CZ, DE, DK, EE, ES, FI, GB, GD, GE, GH, GM, HR, HU, ID, IL, IN, IS, JP, KE, KG, KP, KR, KZ, LC, LK, LR, LS, LT, LU, LV, MD, MG, MK, MN, MW, MX, NO, NZ, PL, PT, RO, RU, SD, SE, SG, SI, SK, SL, TJ, TM, TR, TT, UA, UG, US, UZ, VN, YU, ZA, ZW, ARIPO patent (GH, GM, KE, LS, MW, SD, SL, SZ, UG, ZW), Eurasian patent (AM, AZ, BY, KG, KZ, MD, RU, TJ, TM), European patent (AT, BE, CH, CY, DE, DK, ES, FI, FR, GB, GR, IE, IT, LU, MC, NL, PT, SE), OAPI patent (BF, BJ, CF, CG, CI, CM, GA, GN, GW, ML, MR, NE, SN, TD, TG).</p> <p>Published <i>With international search report.</i></p> <p>(88) Date of publication of the international search report: 16 November 2000 (16.11.00)</p>	

(54) Title: VASCULAR SUCTION CANNULA, DILATOR AND SURGICAL STAPLER

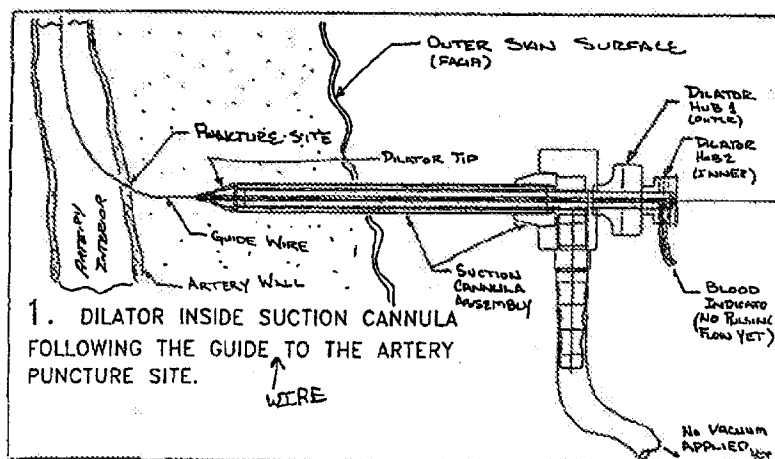

(57) Abstract

A suction cannula (10), dilator (40), stapler (80) and staple (70) are provided herein. The stapler (80) is constructed to slide into the suction cannula (10) to approach a puncture in an artery, and to permit stapling of the artery.

CLAIMS

- 1
- 2 1. A cannula for vascular or tissue procedures, comprising a first tube and a
3 second tube each having a distal and proximal end, the first tube being located
4 coannularly within the second tube thereby defining a passage between the first and
5 second tubes, a hub section located at the proximal end of said first and second tubes,
6 a tip section located at the distal end of said first and second tubes, said hub section
7 including a port for creating a vacuum within said passage through to said tip section,
8 said tip section being formed to surround a portion of tissue and maintain a vacuum
9 pressure thereon.
- 10 2. A cannula as claimed in claim 1, wherein the inside diameter of said first tube
11 being sized to fit around an incision created in an artery, vein and/or other tissue.
- 12 3. A cannula as claimed in claim 1, wherein the inside diameter of said first tube
13 being sized to permit ingress and egress of a dilator.
- 14 4. A cannula as claimed in claim 1, wherein the inside diameter of said first tube
15 being sized to permit ingress and egress of a tissue stapler.
- 16 5. A cannula as claimed in claim 1, wherein said first and second tubes being
17 formed of plastic.
- 18 6. A cannula as claimed in claim 1, further comprising a plurality of support
19 members to hold said first and second tubes in a fixed relationship with respect to one
20 another.
- 21 7. A cannula as claimed in claim 1, further comprising an outer sheath member
22 formed over said second tube and being slidably mounted over said second tube.
- 23 8. A cannula as claimed in claim 7, wherein said outer sheath member being
24 located past said distal portion and tapering to a tip section of a dilator, wherein said
25 taper being adapted to hold said tip section of said dilator until said sheath is slid
26 proximally against said second tube.
- 27 9. A dilator for dilating an incision site, comprising a tubular member having a
28 distal portion and a proximal portion, said distal portion comprising a tapered tip
29 section having a collapsible portion, said proximal portion including a hub section in
30 communication with said collapsible portion, said proximal portion, distal portion and

WO 00/07640

PCT/US99/16476

- 1 tubular member being in fluid communication with one another, and a blood
2 indication port to indicate the presence of blood at said tip section.
- 3 10. A dilator as claimed in claim 9, wherein said collapsible portion comprising a
4 resiliently deformable section that can be closed in a radial direction, said collapsible
5 portion including an O-ring member that can be actuated by a slidable hub section
6 located at said proximal end to close said collapsible portion.
- 7 11. A dilator as claimed in claim 9, further comprising another tubular member
8 within said tubular member for passage of a guidewire therein to locate an incision
9 site.
- 10 12. A dilator as claimed in claim 10, wherein said collapsible portion being
11 collapsible in the radial direction sufficient to permit said tip section to pass within a
12 cannula.
- 13 13. A dilator as claimed in claim 10, wherein said collapsible tip section being of
14 larger cross-sectional diameter than said tubular member when said collapsible tip
15 section is not collapsed, and of equal or smaller diameter when said collapsible tip
16 section is closed.
- 17 14. A dilator as claimed in claim 10, wherein said tubular member having an
18 outside cross-sectional diameter to fit within a cannula.
- 19 15. A tissue stapler for deploying a staple into tissue, comprising a tubular
20 member having a tip section, a trigger, and a connecting rod between said tip section
21 and trigger located within said tubular member, said tip section comprising a staple
22 deploying member located on said tubular member and formed about said tip section,
23 a flange section located on said connecting rod having a flange member adapted to
24 hold a staple between said flange member and said staple deploying member, said
25 connecting rod and said tip section slidably engaged by said trigger to slid said
26 connecting rod toward said tip section thereby deploying said staple.
- 27 16. A stapler as claimed in claim 15, wherein said connecting rod being rotatable
28 within said tubular member, and said flange section being mated with an opening in
29 said staple in one dimension, wherein said staple is placed over said flange member

WO 00/07640

PCT/US99/16476

1 and wherein, upon rotation of said connecting rod, said staple being held against said
2 deploying member by said flange member.

3 17. A stapler as claimed in claim 16, wherein said flange member having a
4 generally oval shape and said opening in said staple having a mated oval shape.

5 18. A stapler as claimed in claim 15, wherein said trigger comprises a lever for
6 moving said connecting rod against said tip section.

7 19. A stapler as claimed in claim 18, wherein said trigger further comprises a
8 spring mechanism between said lever and said connecting rod to hold said connecting
9 rod against said deploying member until movement of said lever.

10 20. A stapler as claimed in claim 15, wherein said staple comprising a plurality of
11 tissue engaging prongs that are crimped together at least partially through said tissue
12 by said deploying member.

13 21. A stapler as claimed in claim 15, wherein said deploying member having a
14 generally parabolic shape.

15 22. A stapler as claimed in claim 15, wherein said deploying member having a
16 plurality of slidable finger members being actuated by said trigger to slide axially over
17 said connecting rod and flange member to crimp said staple.

18 23. A method of performing a series of intravascular diagnostic, interventional
19 and/or therapeutic procedures at an incision site comprising the steps of:

20 following a guide wire down to an artery or vein with a combination dilator
21 within a cannula;

22 positioning at least a tip portion of the dilator within an artery or vein and
23 indicating that the tip is within an artery or vein by the presence of blood;

24 applying suction to at least a portion of said cannula and communicating said
25 suction to the walls of the artery or vein, thereby fixing the cannula on said walls;

26 removing the dilator from within the cannula;

27 maintaining suction on said cannula to permit said cannula to remain located
28 about said opening within the wall of the artery or vein.

29 24. A method as claimed in claim 23, further comprising the steps of:

WO 00/07640

PCT/US99/16476

1 performing intravascular diagnostic, interventional and/or therapeutic
2 procedures using the cannula as a locator to the artery or vein;

3 stapling or suturing the artery or vein, using the cannula as a locator to the
4 opening within the artery or vein; and

5 removing said suction and removing said cannula.

6 25. A staple and a stapler for stapling tissue, said stapler comprising a tubular
7 member having a tip section, a trigger, and a connecting rod between said tip section
8 and trigger located within said tubular member, said tip section comprising a staple
9 crimping member located on said tubular member and formed about said tip section, a
10 flange section located on said connecting rod having a flange member adapted to hold
11 a staple between said flange member and said staple crimping member, said
12 connecting rod and said tip section slidably engaged by said trigger to slide said
13 connecting rod toward said tip section thereby crimping said staple; said staple
14 comprising a ring member defining an opening therein, said opening being mated to
15 fit over said flange member in one dimension and a plurality of tissue engaging
16 members located on said ring member to pierce into tissue upon crimping by said
17 stapler.

18 26. A staple and a stapler as claimed in claim 25, wherein said flange member and
19 said opening having mated shapes.

20 27. A staple and a stapler as claimed in claim 25, wherein said connecting rod
21 being rotatable within said tubular member, and said flange section being mated with
22 an opening in said staple in one dimension, wherein said staple is placed over said
23 flange member and wherein, upon rotation of said connecting rod, said staple being
24 held against said crimping member by said flange member.

25 28. A cannula as claimed in claim 1, wherein said first and second tubes being a
26 closed, elongated tubular members and being connected to one another in a fixed
27 coannular relationship by one or more connecting members.

28 29. A cannula as claimed in claim 1, wherein said second tube being a closed,
29 elongated tubular member and said first tube having a tubular cross section and
30 comprising one or more elongated arcuate segments disposed within said second tube,

WO 00/07640

PCT/US99/16476

1 said arcuate segments being fixed to said second tube by one or more connecting
2 members.

3 30. A cannula as claimed in claim 29, wherein the space between said second tube
4 and said arcuate segments defining said passage for creating said vacuum.

5 31. A cannula as claimed in claim 29, wherein said connecting members further
6 defining another second passage in relation to said arcuate segments, said second
7 passage being chosen to permit one or more instruments to pass therethrough.

8 32. A cannula as claimed in claim 1, wherein said cannula being used for
9 diagnostic, interventional and/or therapeutic procedures.

10

WO 00/07640

PCT/US99/16476

1 **VASCULAR SUCTION CANNULA, DILATOR AND SURGICAL STAPLER**

2 **BACKGROUND OF THE INVENTION**

3 **1. Field of the Invention**

4 The present invention relates to a vascular suction device, a dilator and a
5 stapler for the closure of a puncture made in the wall of an artery or vein during a
6 medical procedure. The present invention has particular utility for use in and around
7 the femoral artery during and after coronary/cardiac procedures. Other utilities
8 include soft-tissue anchoring, meniscal repair, thoracic lung closure, endoscopic
9 procedures, esophageal repair, laparoscopy, skin/epidermal wound closure and general
10 tissue closure.

11 **2. Description of Related Art**

12 Surgical stapling instruments, dilators and cannulas for diagnostic,
13 interventional and/or therapeutic medical procedures are known. For example, U.S.
14 Patent No. 5,709,335 issued to Heck discloses a wholly distal surgical stapling
15 instrument for stapling a tubular tissue structure to a luminal structure, such as a
16 vascular lumen. This device can be used for anastomotic stapling of a tubular vessel
17 having two untethered ends, and is especially useful for making the primary
18 anastomotic connection of a bypass vein to a coronary artery or to the aorta. The
19 device essentially includes a rod that is placed within the tubular vessel and an anvil
20 that forces staples (associated with the rod) to bend outwardly against the vessel and a
21 target (such as a coronary artery). Thus, this device requires that the stapler device be
22 placed within the tubular vessel (e.g., vein or artery) for operation. While this device
23 is useful when stapling a graft vein or the like, unfortunately, this device would be
24 inappropriate when the entirety of the tubular tissue is not accessible, such as
25 following percutaneous catheterization procedures.

26 Another example can be found in U.S. Patent No. 5,403,333 issued to Kaster
27 et al. This patent discloses a side-to-end anastomotic staple apparatus for use where
28 the end of a blood vessel becomes connected to the side or wall of a second blood
29 vessel or other structure, such as the heart. Similar to the previous discussion, this
30 device requires that at least one end of the vessel be open, so that a stapling

WO 00/07640

PCT/US99/16476

1 mechanism can be inserted therethrough. As noted above, many surgical procedures
2 only access a portion of the vessel. Thus, this device would not be useful in these
3 circumstances.

4 Yet another example, U.S Patent No. 5,695,504 issued to Gifford, III et al.,
5 discloses an end-to-side vascular anastomosis device to perform end-to-side
6 anastomosis between a graft vessel and the wall of a target vessel. This device
7 involves a procedure in which the end of a graft vessel is passed through an inner
8 sleeve of the device until the end of the vessel extends from the distal end of the
9 device. The distal end of the graft is then affixed to the wall of the target, using a
10 staple and stapler which forces a staple into both tissues. Similar to the previous
11 disclosures, this device is useful for the attachment of one tubular tissue onto another,
12 however, is inadequate in sealing a puncture in an artery, vein or other tissue left by
13 certain medical procedures.

14 Other examples can be found in the art. However, these devices are often
15 complicated to manufacture and use, requiring expensive tooling and materials. It is
16 often the case that staplers, cannulas and dilators are single application or procedure
17 devices, which must be discarded after use. Thus, there is a need to provide an
18 efficient stapler mechanism that is simple to use and relatively easy to manufacture,
19 since the device is likely to be discarded after only one use. Moreover, the prior art
20 has failed to provide a device that permits a doctor or clinician to gain access to a
21 puncture site and remain centered on that site throughout the entire procedure,
22 including closure of the puncture, or to ensure that the closure mechanism is delivered
23 over and/or around the puncture site.

24 Summary of the Invention

25 Thus, the present invention solves the aforementioned drawbacks by providing
26 a suction cannula, dilator, stapler and staple that are simple to use and manufacture.
27 In one aspect, the present invention provides a suction cannula that is concentrically
28 aligned with a puncture site (e.g., puncture in an artery or vein) and provides vacuum
29 about the periphery of the puncture site so that the puncture hole is always located
30 during a medical procedure, and to thereby permit a surgeon to quickly and efficiently

WO 00/07640

PCT/US99/16476

1 close the puncture using, for example, a stapling device. In the preferred embodiment
2 the suction cannula has a tube-in-tube construction having an inner tube and an outer
3 tube where a vacuum can be applied between the tubes.

4 In another aspect, the present invention provides a dilator, which can be placed
5 within the inner tube of the suction cannula during insertion into the body. The
6 dilator (and suction cannula) centers around a guide wire (that is already in place
7 within the venous structure) and follows the path of the guide wire to the puncture
8 site. Preferably, the dilator has a tapered tip on the distal end that follows the
9 guidewire through the puncture hole made in the vein or artery. A blood indicator is
10 provided on the proximal end to provide visual feedback when the surgeon is in the
11 artery (i.e., pulsating blood indicates that the tip of the dilator is in the artery). In one
12 preferred embodiment, the dilator includes a tapered tip on the distal end that is
13 radially collapsible so that the dilator can be withdrawn from the artery and the
14 suction cannula is thereby permitted to advance over the dilator to the artery wall. To
15 that end, indicators on the external, proximal end of the dilator provide the user with a
16 visual measurement as to the distance to the artery wall. Once the suction cannula
17 makes contact with the vascular wall, and vacuum can be applied to the cannula so
18 that the cannula remains concentrically aligned with the puncture in the vessel, and
19 the dilator can be removed.

20 In yet another aspect of the present invention, a stapler is provided which
21 holds a multi-pronged staple on a shaft at the distal end. The distal portion of the
22 stapler is constructed to fit within the suction cannula (i.e., the inner tube of the
23 cannula) to approach the puncture in the wall of the artery (or other soft tissue), to
24 permit the stapling of the artery. Preferably, the distal end of the stapler includes a T-
25 flange that retains a staple, and a deploying mechanism that deploys the staple into the
26 artery, thereby sealing the puncture. Deployment of the staple can include crimping
27 of the staple through the vascular wall and/or partial insertion of the staple into the
28 tissue. The T-flange permits the staple to be retained on the distal end of the stapler
29 and deployed into the artery wall. An oval hub on the T-flange is provided that mates
30 with an oval hole in the center of the staple. To hold a staple, a staple is placed on the

WO 00/07640

PCT/US99/16476

1 hub and rotated 90 degrees, thereby affixing the staple to the stapler. Once the staple
2 is crimped onto the artery wall, the shaft can be rotated 90 degrees, thereby aligning
3 the oval hub and the oval hole, so that the stapler can be removed. Preferably, the
4 staple includes a plurality of prongs that are inserted into the vascular wall.

5 Advantageously, the suction cannula of the present invention permits the
6 surgeon to remain centrally located about a puncture site throughout the entire
7 procedure, from incision to closing. The suction cannula permits a surgeon to enter an
8 incision, and using a dilator as an artery indicator, secure the cannula to the artery
9 wall, via vacuum force, about the puncture site. Also advantageously, this permits the
10 surgeon to view and approach the puncture site (using a catheter, for example)
11 throughout the entire procedure, without obstruction. In addition, a stapler and staple
12 are provided which can be guided down the shaft of the cannula to quickly seal the
13 puncture site.

14 It will be appreciated by those skilled in the art that although the following
15 Detailed Description will proceed with reference being made to preferred
16 embodiments, the present invention is not intended to be limited to these preferred
17 embodiments. Other features and advantages of the present invention will become
18 apparent as the following Detailed Description proceeds, and upon reference to the
19 Drawings, wherein like numerals depict like parts, and wherein:

20 BRIEF DESCRIPTION OF THE DRAWINGS

21 Figure 1 is a longitudinal cross-sectional view of one embodiment of the
22 suction cannula of the present invention;

23 Figure 2 is a cross-sectional view of the hub portion of the suction cannula of
24 FIG. 1;

25 Figure 3A is an enlarged cross-sectional view of the distal end of the suction
26 cannula of FIG. 1;

27 Figure 3B is an end-on cross sectional view of the distal end of the suction
28 cannula of FIG. 3A;

29 Figure 4 is a detailed view of the distal end of one embodiment of the dilator
30 of the present invention;

WO 00/07640

PCT/US99/16476

1 proximal end 12 and a distal end 14. The distal end 14 is adapted to permit vacuum
2 affixation of the cannula 10 to a vascular wall, or other tissue as will be described
3 below. As shown in FIG. 3B, the tubular member 30 is preferably constructed with a
4 tube 20 within a tube 18. As will be described below, the chamber 22 between the
5 tubes 18 and 20 is used as a vacuum chamber. Passage 24 permits a dilator and/or
6 stapler device (each discussed below) and/or other surgical devices to pass
7 therethrough. Support members 26 are provided to concentrically affix tubes 18 and
8 20. The proximal end 12, as shown in FIG. 2 includes a vacuum port 28 that can be
9 attached to an external vacuum (not shown). Vacuum port 28 communicates with
10 chamber 22 (between inner tube 20 and outer tube 18) to provide a vacuum therein.
11 As shown in FIG. 3A, a flexible tip section is provided on the distal end 14 of the
12 cannula to provide a secure vacuum interface between cannula 10 and a vascular wall.
13 Preferably, the flexible tip section is formed of pliable rubber or other equivalent
14 materials.

15 Figure 4 depicts one preferred embodiment of a dilator 40, used in conjunction
16 with the suction cannula 10, described above. The dilator includes a tubular structure
17 50, a distal end 52 and a proximal end 54 (not shown in Figure 4). The tubular
18 structure 50 is intended to pass within the inner tube 20 of the suction cannula 10.
19 Thus, the diameter of tubular structure 50 is preferably manufactured to the tolerance
20 of the inner tube 20, to permit unobstructed ingress and egress of the dilator 40 within
21 the cannula 10. The distal end 52 preferably includes a dilator tip 44, a passage 46 for
22 a guide wire 48, and a collapsible section 42 that can be hand-manipulated to expand
23 and contract (described below). Additionally, another tube 45 is provided within tube
24 50 in fluid communication with opening 47 and hub (described below) to allow blood
25 to flow within tube 45. Tube 45 can be eccentrically disposed within tube 50 (as
26 shown), or, tube 45 can be concentrically disposed within tube 50. Referring to
27 Figure 8, the proximal end 54 of the dilator includes a movable hub 56. A cam
28 mechanism 62 connected between movable hub 56 and collapsible section 42 (via one
29 or more connecting members, not shown) that engages an O-ring 60 to collapse and/or
30 expand section 42. Preferably, when section 42 is expanded, the diameter of section

1 42 is larger than the diameter of tube 20, thereby locking the dilator 40 against the
2 cannula tube 30 (described herein). When it is desired to remove the dilator from the
3 cannula, section 42 is collapsed so that the dilator can pass within tube 20 of the
4 cannula 30.

5 Figure 4A depicts an alternative embodiment for the tip section 44' of the
6 dilator depicted in Figure 4. In this embodiment, tip section 44' has an elongated
7 shape, as compared with the embodiment in Figure 4. Like the previous embodiment,
8 opening 47' permits fluid to flow within region 49, which is disposed within tube 50
9 around tube 45'. Unlike the previous embodiment, tube 50' and tip 44' are not fixed
10 within the cannula 30. Rather, tube 50 and tip 44' can be inserted into and withdrawn
11 from the cannula with relatively little obstruction.

12 Figure 5 depicts the preferred embodiment of the surgical staple 70 of the
13 present invention. Staple 70 includes an oval member 76 with a plurality of prongs 72
14 around the circumference of oval member 76. Oval member 76 defines an oval
15 opening or hole 74, which cooperates with a stapler (described below). As will be
16 described in more detail with reference to the stapler device, prongs 72 crimp onto the
17 vascular walls (or other tissue) to effectively seal a puncture. Figure 6A shows a view
18 of the distal end of the stapler 80 of the preferred embodiment. The distal end
19 includes a slidable crimping member 82 and a flange member 84. As shown in FIG.
20 6E, flange member 84 is shaped to match the inner diameter of oval member 76 of the
21 staple 70. In use, staple 70 is inserted over flange member 84 so that staple 70 abuts
22 shaft member 86 adjacent flange member 84. Staple 70 is rotated approximately 90
23 degrees, as depicted in FIG. 6D, thereby locking the staple between flange 84 and
24 shaft 86. Flange member 84 is connected to connecting rod 100 (as shown in Figs 11
25 and 15) passing through the stapler device to the proximal end. Accordingly, key hub
26 98, which is also connected to connecting rod 100 (and thus, flange member 84) can
27 be rotated approximately 90 degrees, thereby releasing the staple 70 from the staple
28 device. In the preferred embodiment, key hub is hand rotatable. Although, key hub,
29 connecting rod and flange member can also be automatically rotated through the
30 action of the driving mechanism and handle, 96 and 94.

1 Figures 6B and 6C depict insertion of the staple into the vascular wall (or
2 other tissue) and crimping of the staple, respectively, using the stapler 80, described
3 above. Crimping member 82 is first slid toward the vascular wall so that the staple 72
4 pierces the wall (FIG. 6B). It will be understood that the members 72 can include a
5 sharp or pointed edge 88 to aid the insertion of staple 70 into the vascular wall.
6 Crimping member 82 is then further advanced toward the vascular wall to force the
7 staple to crimp, due to the force direction exerted by the conforming portion 90 onto
8 the staple (FIG. 6C). In this embodiment, conforming portion 90 includes a generally
9 parabolic shape. Once the staple is crimped, the flange member 84 can be rotated
10 (e.g., rotated 90 degrees, via connecting rod 100 and key hub 98) so that hole 74 and
11 flange 84 are aligned, and the stapler can be withdrawn from the vascular wall.

12 Referring to Figure 6F, another embodiment of a staple 76' of the present
13 invention. The staple of this embodiment cooperates with the flange member 84',
14 crimping member 82', conforming portion 90' and connecting rod 86' as in the
15 previous embodiment. Included in this embodiment is membrane 130. Member 130
16 is formed on the staple between members 72' such that the opening 74 (not shown) is
17 covered. The membrane 130 is preferably formed to permit unobstructed ingress and
18 egress of flange 84' within the opening 74, as shown in the drawing. Membrane 130
19 is formed of silicon, elastomer, or bioabsorbable material. Essentially, membrane 130
20 is provided to seal the puncture hole in the vascular wall that may remain unsealed
21 due to the opening 74 of the staple 76'.

22 Figures 7 – 19 depict detailed functionality of the cannula 10, dilator 40, staple
23 70 and stapler 80 (as described above with reference to FIGS. 1-6E) of the present
24 invention. As shown in FIG. 7, the suction cannula 10 and the dilator 40 are inserted
25 into the incision in the skin (facia), following the previously-inserted guide wire 48,
26 toward the arterial puncture site. Although not shown in these drawings, the guide
27 wire can be removed at any stage of the proceeding process, or may be left within the
28 cannula as a reference point. It should be noted that with reference to the stapling
29 procedure described herein, it is preferable that the guide wire be removed. When the
30 tip 44 of the dilator 40 enters the puncture site, pulsating blood at the proximal end 54

WO 00/07640

PCT/US99/16476

1 of the dilator provides visual feedback, as shown in FIG. 8. Importantly, the dilator
2 provides concentric alignment with the puncture site about the guide wire. Once
3 inside the artery, the tip is collapsed (as described above) by pulling back on the
4 proximal hub 56 of the dilator, while simultaneously the cannula 10 is advanced over
5 the dilator tip (distally) to engage the artery wall, as shown in FIG. 9. Graduated
6 markings 90 on the dilator provide an indication of the relative distance to the artery
7 wall. As shown in FIG. 10, the dilator is removed and vacuum source 92 is applied to
8 the cannula to secure the cannula to the artery wall. Advantageously, using the
9 cannula as described herein, unobstructed access to a puncture site is obtained,
10 permitting a surgeon to perform intravascular procedures without the need for various
11 "changouts" of instruments to locate the puncture site.

12 Once the diagnostic, interventional, therapeutic, or other procedure (following
13 the cannula to the puncture site) is complete, the puncture site is to be closed. As
14 shown in FIG. 11, the stapler 80 (with a staple 70 secured on the distal end, as
15 described above) is inserted down the cannula to the puncture site. The staple 70 is
16 pushed into the vascular wall sufficiently to allow the staple to at least partially pierce
17 the wall, as shown in the close-up view of FIG. 12. As shown in FIGS. 13 and 14, the
18 surgeon activates a lever 94, which, in turn activates driving mechanism 96 to drive
19 crimping member 82 distally, to thereby crimp the staple and seal the puncture site (as
20 described above). As shown in the figures, driving mechanism 96 is contained within
21 handle 108. More specifically, mechanism 96 preferably includes a spring 102
22 housed in housing 104. Spring 102 is connected to lever 94 (via connecting hub 110)
23 and crimping member 82, so that movement of handle 94 provides distal and proximal
24 movement to crimping member 82. Spring member preferably keeps handle 94 and
25 crimping member 82 in the relative positions shown in Fig. 11 and 6A, respectively.
26 Thus, movement of the handle 94 as indicated by the arrow in Figure 11 causes
27 crimping member 84 to be forced against the staple for closure (crimping), as
28 described above. Once crimped, a key hub 98 on the stapler is rotated to turn the shaft
29 86 approximately ninety degrees to align opening 74 of staple 70 with flange 84, as
30 shown in FIG. 15. This permits disengagement of the staple 70 from the stapler 80, so

WO 00/07640

PCT/US99/16476

1 that the stapler can be removed from the cannula, as shown in FIGS. 16 and 17. After
2 the stapler is removed the stapled puncture site can be inspected (down the cannula) to
3 ensure that the puncture site is correctly sealed (FIG. 19). In addition, the guide wire,
4 if not previously removed, can be removed at this point. The vacuum is disengaged to
5 permit the cannula to be removed from the incision in the skin, as shown in FIG. 18.
6 It should be noted that other geometric configurations of the flange member and staple
7 will necessitate an alternative rotation, which may be other than approximately 90
8 degrees.

9 The preferred material used for the construction of the devices shown in all the
10 figures can include plastic, stainless steel, titanium, and bioabsorbable material (where
11 appropriate).

12 Modifications to the present invention are also possible. For example, instead
13 of a stapling device 80, as described above, an appropriate suturing mechanism, laser
14 suturing mechanism, or other closure system can be used to seal the puncture site. In
15 any event, the suction cannula 10 provides unobstructed access to the puncture site
16 during medical procedures, including closure of the wound. The driving mechanism
17 96 of the stapler could be appropriately modified with a push-button activated gear
18 mechanism to slide the crimping member distally. Those skilled in the art will
19 recognize that many modifications are possible to drive the crimping member, and all
20 such modifications are deemed within the scope of the present invention.

21 The shape of the staple 70 / flange 84 can also be modified. For example, the
22 member 76 can modified and shaped as a rectangle, triangle, square, etc.
23 Alternatively, the member 76 can include a circular shape which is friction fit over the
24 flange member. Accordingly, the flange 84 would be appropriately modified to match
25 the opening 74 defined by the member 76 to permit engagement and disengagement
26 of the staple 70 and flange 84, as described above. The staple 70 can be further
27 modified with barbs on the prongs 72, to provide a more secure fastening of the staple
28 to the artery wall.

WO 00/07640

PCT/US99/16476

1 The crimping member 82 can be modified to include a conforming portion 90 having
2 a variety of shapes, provided that the overall functionality of the crimping member, as
3 described herein, is not hindered.

4 The vacuum source applied to the cannula 10 can be any conventionally
5 known automated vacuum supply. Of course, the cannula can be appropriately
6 modified to include a manually activated vacuum using, for example, a bulb
7 mechanism, when a vacuum supply is otherwise unavailable.

8 Additional modifications are also possible. Referring to Figures 20-23, an
9 alternative embodiment for the cannula and dilator are shown. In this embodiment, an
10 outer sheath 110, preferably formed of plastic, is placed over the cannula 112 with the
11 dilator 114 inserted into the cannula. The plastic sheath 110 is slidably engaged the
12 over cannula using hub 120. As shown in Figures 21 and 23, the sheath 110 locks the
13 distal tip 116 of the dilator 114 at juncture 118. Retracting the sheath 110 is
14 accomplished by pulling proximally on hub 120, thereby opening the wing members
15 122 of the sheath 110. To that end, a latch 132 can be provided that holds the hub 120
16 in place. Preferably, latch 132 can be manually removed from the hub 120 to permit
17 movement of the hub. Additionally, snap-fit interference locks 134a and 134b can be
18 provided as shown to fix the hub (and sheath) in the proximal position, as indicated by
19 the arrow. The cannula 112 may be of the type described above. Alternatively,
20 instead of the tube-in-tube suction cannula set forth herein, the cannula can be
21 modified so that only the distal tip 124 has a tube-in-tube construction. In other
22 words, referring to Fig. 1-3A, the tube-in-tube construction need not span the entire
23 length of the device, but may rather only be provided at the tip section 124,
24 recognizing that the stapler, dilator or other instruments will be inserted therein. The
25 distal tip 116 of the dilator 114 is preferably constructed as shown in Figure 23.
26 Preferably, the distal tip can include a passage 126 in fluid communication with the
27 dilator, to provide visual indication within the artery by the presence of blood (shown
28 at the dilator hub section). It should be noted that the dilator tip can be elongated
29 (more so than shown in the drawings) thereby reducing the angle of insertion into a
30 vein or artery (as shown in Figure 4A). Also alternatively, instead of a cannula

WO 00/07640

PCT/US99/16476

1 having a tube-in-tube construction as described herein, the cannula 112 can modified
2 to include only a single tube. In this case, the sheath 118 can replace the outer tube 18
3 of the cannula (Figure 1) and a vacuum can be created within the space between the
4 sheath and the cannula.

5 Another embodiment of the cannula 140 of the present invention is depicted in
6 Figure 25A. In this embodiment, an outer tube 142 is provided, similar to the
7 embodiment of Figs. 1-3A. The inner tube, however, is provided as a plurality of
8 arcuate segments 144a - 144d, connected to the outer tube by connecting members
9 148a - 148d. The space between the segments 144a-d and the outer tube 142, shown
10 as 146a-d, is preferably used for the vacuum, as described above. The connecting
11 members 148a-d can also be constructed so as to provide a keyway space 150, which
12 can be keyed to a variety of instruments, as will be described below. It should be
13 noted that the construction shown in Figure 25A can be extruded the entire length of
14 the cannula 140, or provided at the distal tip thereof. It should also be noted that the
15 length of the arcuate segments and the positioning of the connecting members is a
16 matter of design choice for a desired cross-sectional profile.

17 Figures 24A and 24B depict the tip section 160 of another preferred stapler of
18 the present invention. In this embodiment, the tip section 160 includes a conforming
19 portion 162 having a plurality of fingers 164a-d, which are located about the periphery
20 of the section 160, and provided to urge the staple against the flange member
21 (described above). The cooperation of the cannula of Figure 25A and the stapler tip
22 of Figures 24A and 24B is depicted in Figure 25B. As shown in this figure, the space
23 150 permits passage therethrough of the stapler tip 160. Also shown in this drawing
24 is the staple 168 and flange 170, which operate as described herein.

25 Although the detailed description provided herein has largely been in reference
26 to arterial procedures, the present invention is not so limited. The cannula of the
27 present invention can also be used in other tissue environments, as may be required.

28

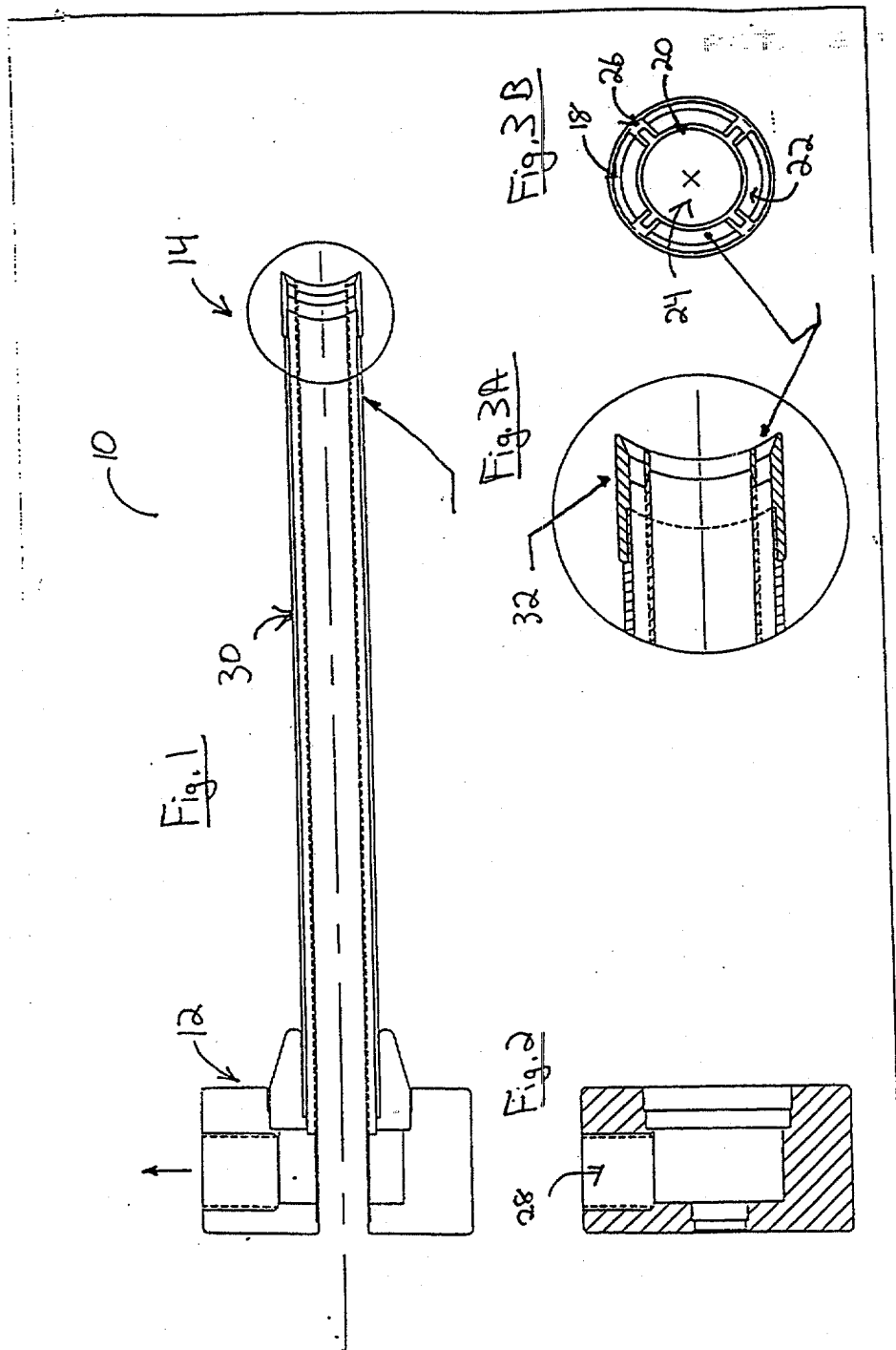

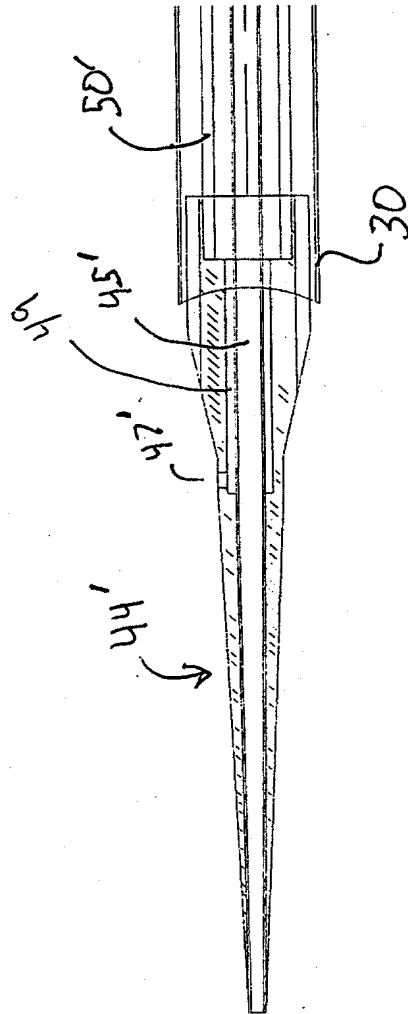

Figure 4A

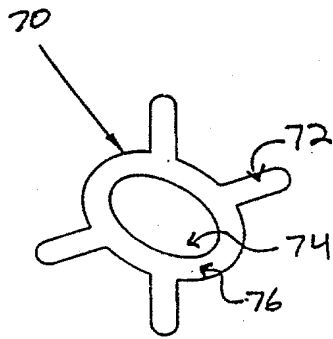

Fig. 5

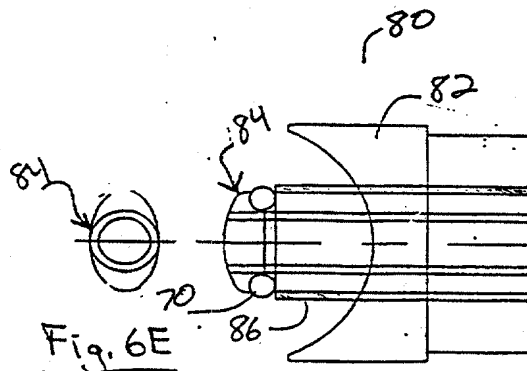

Fig. 6E

Fig. 6A

Fig. 6B

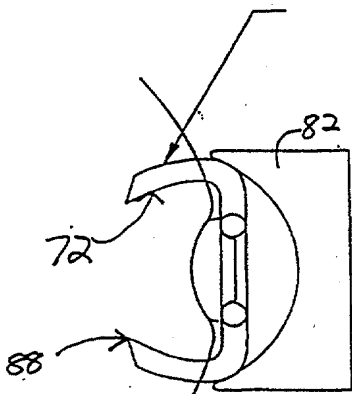

Fig. 6C

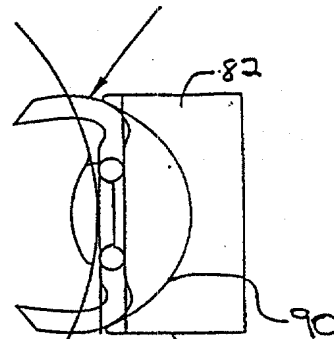
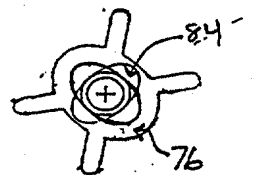

Fig. 6D



vascular wall

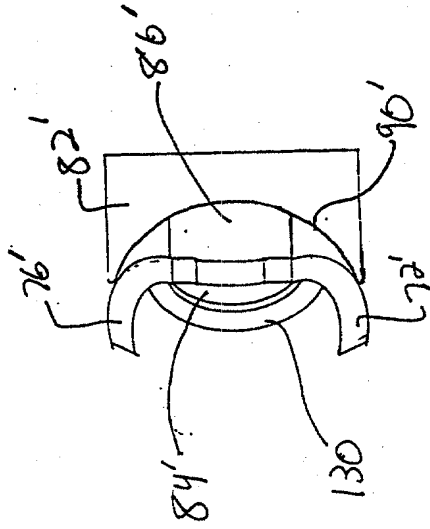

Figure 6F

Fig. 7

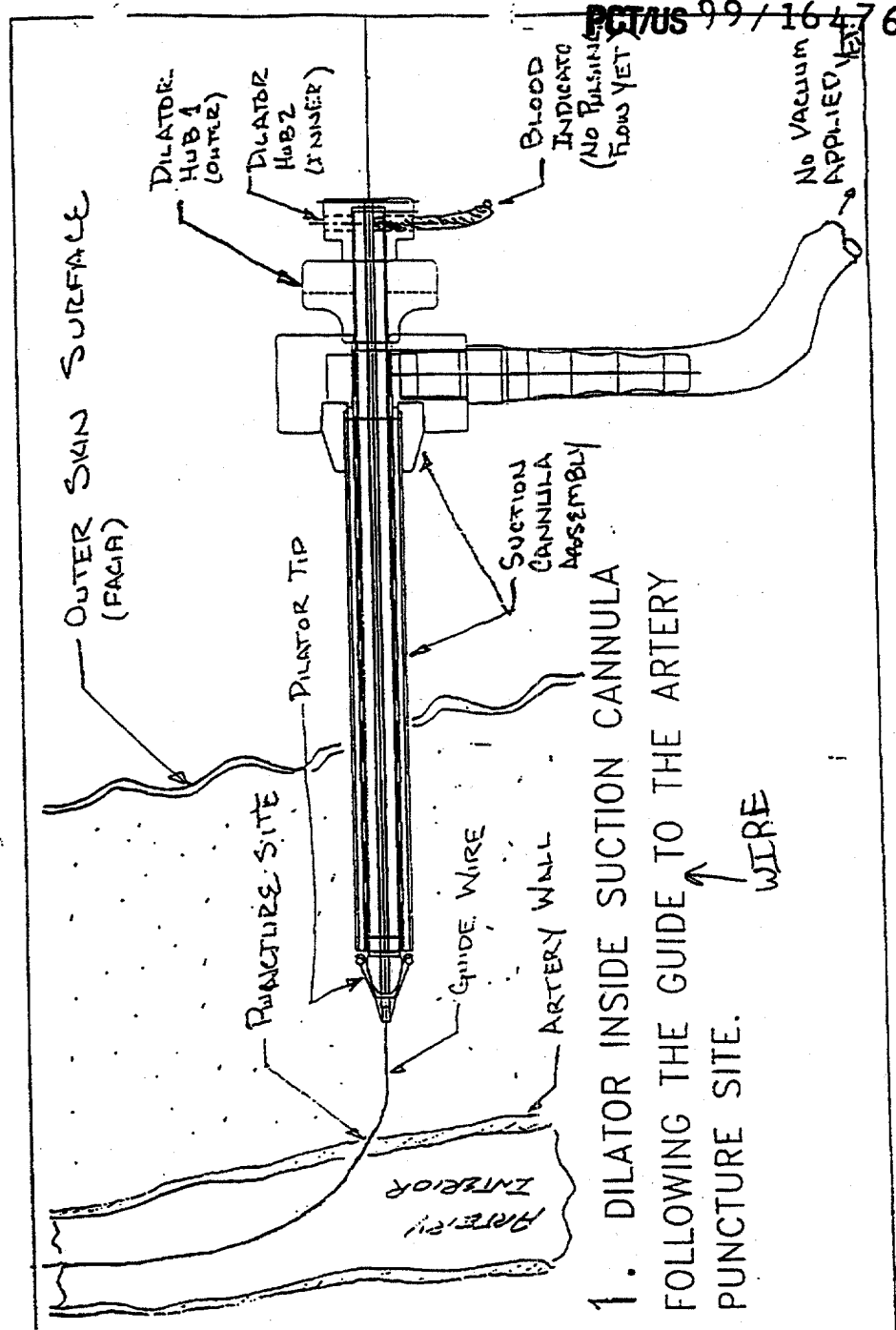
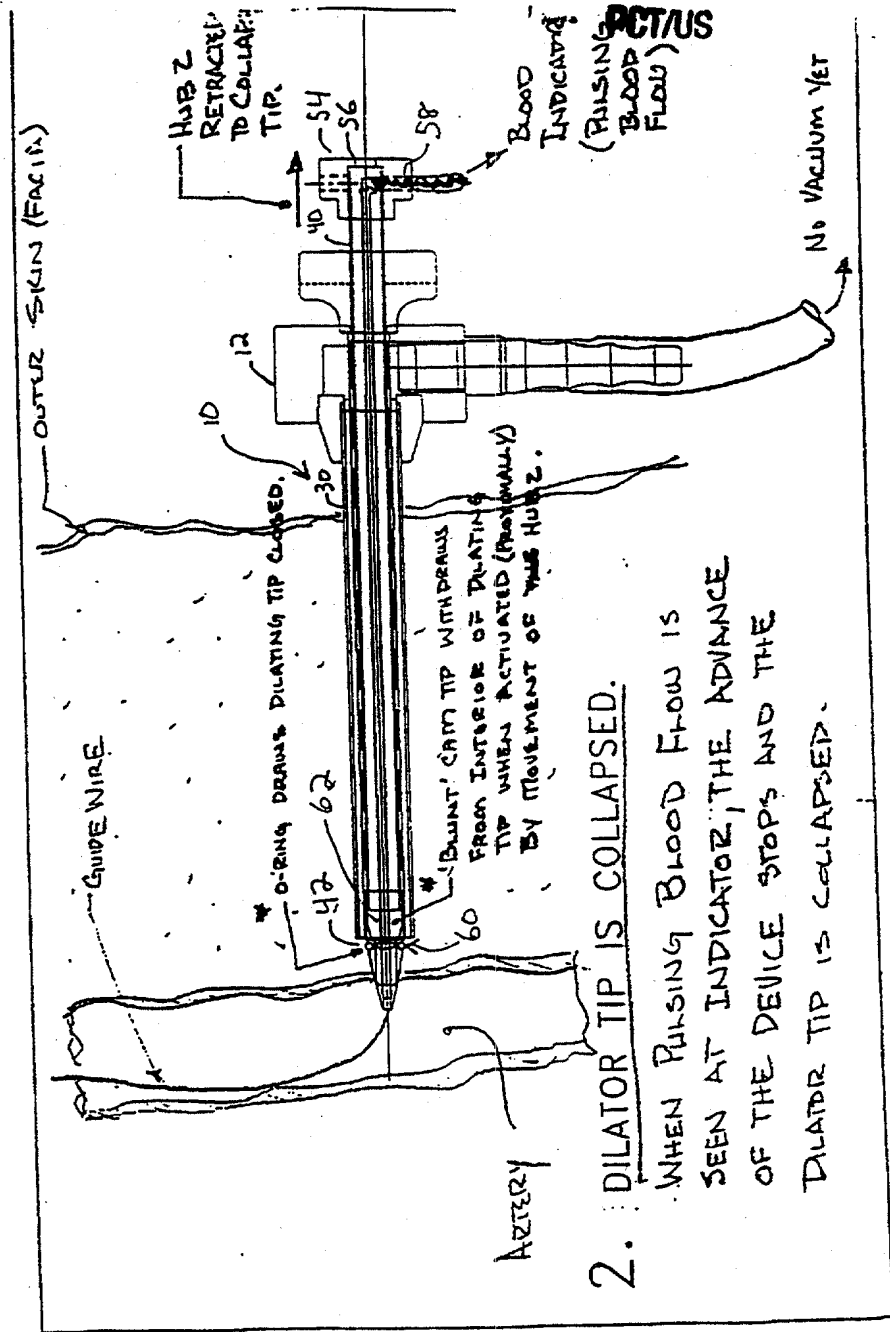

Fig. 8



2. DILATOR TIP IS COLLAPSED.

WHEN PULSING BLOOD FLOW IS SEEN AT INDICATOR, THE ADVANCE OF THE DEVICE STOPS AND THE DILATOR TIP IS COLLAPSED.

Fig. 9

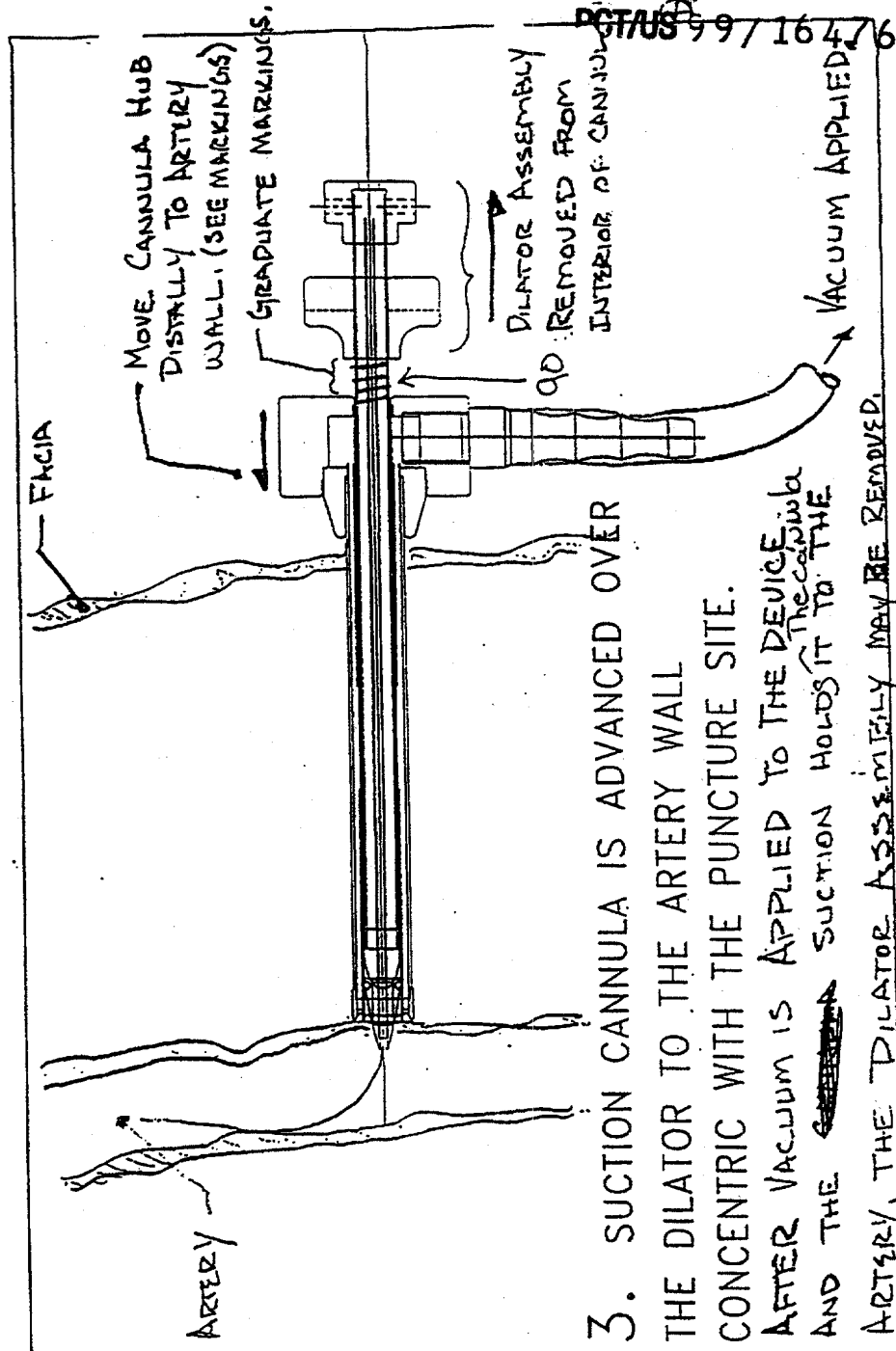

3. SUCTION CANNULA IS ADVANCED OVER THE DILATOR TO THE ARTERY WALL CONCENTRIC WITH THE PUNCTURE SITE. AFTER VACUUM IS APPLIED TO THE DEVICE AND THE ~~CANNULA~~ ^{The cannula} SUCTION HOLDS IT TO THE ARTERY, THE DILATOR ASSEMBLY MAY BE REMOVED.

Fig. 10

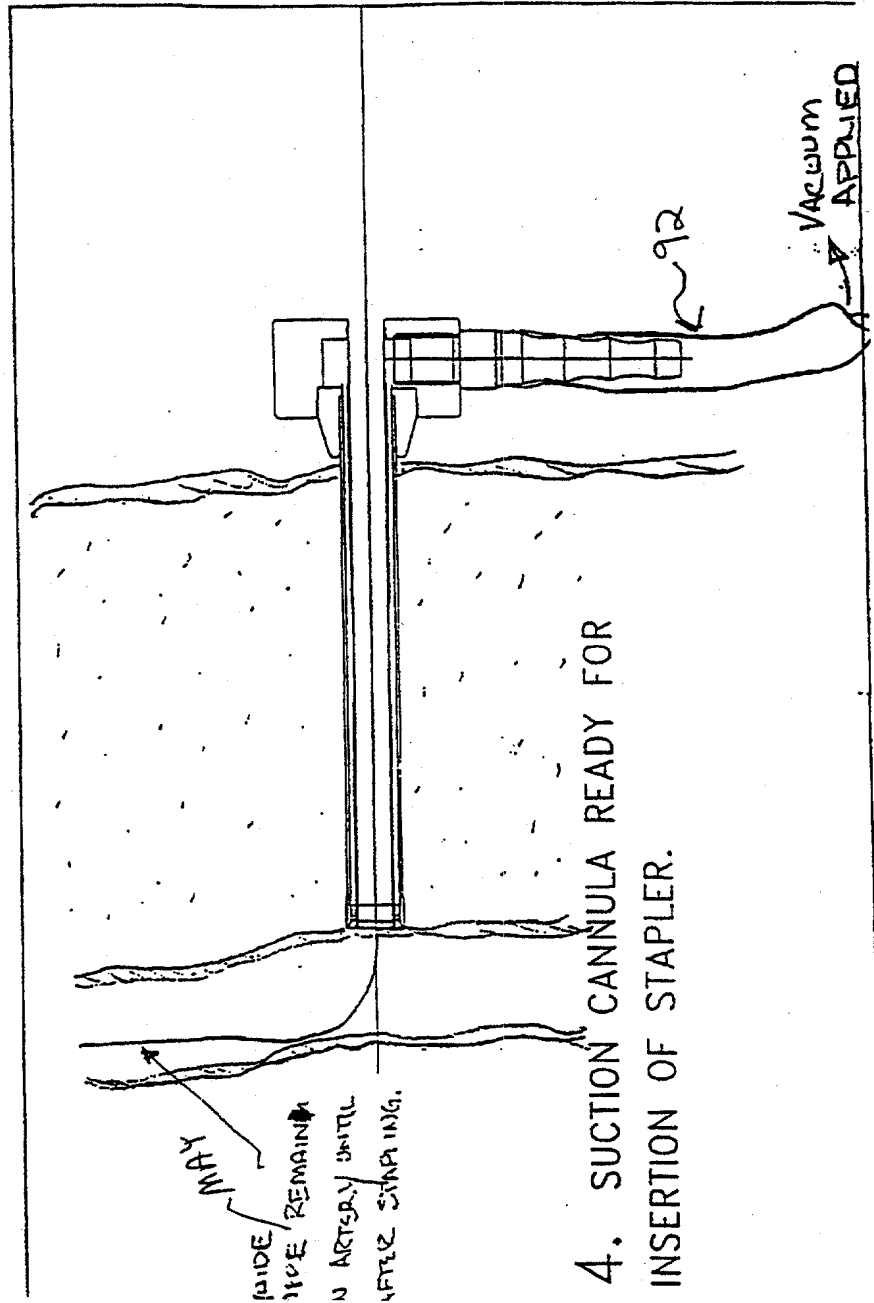

⊕

Fig. 11

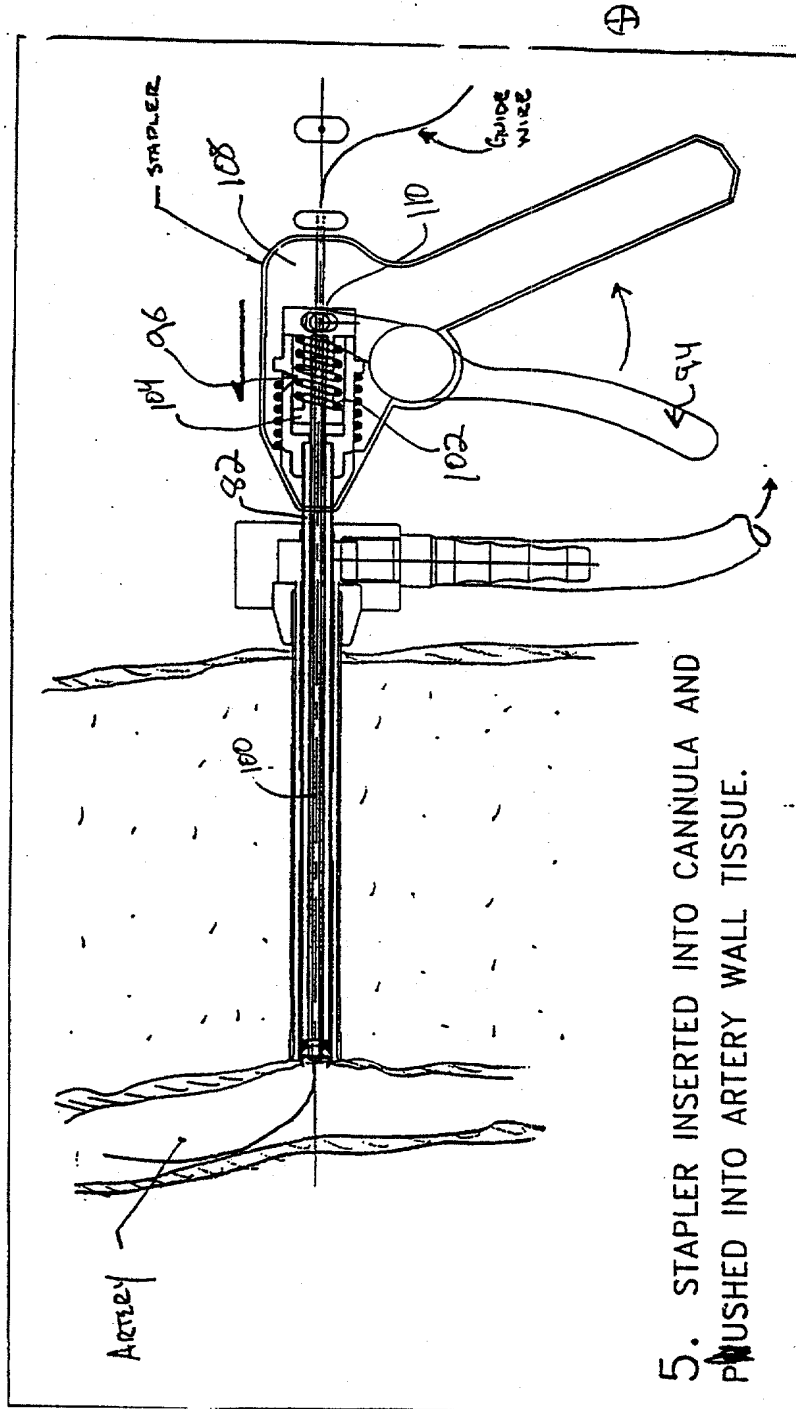

Fig. 1a

5

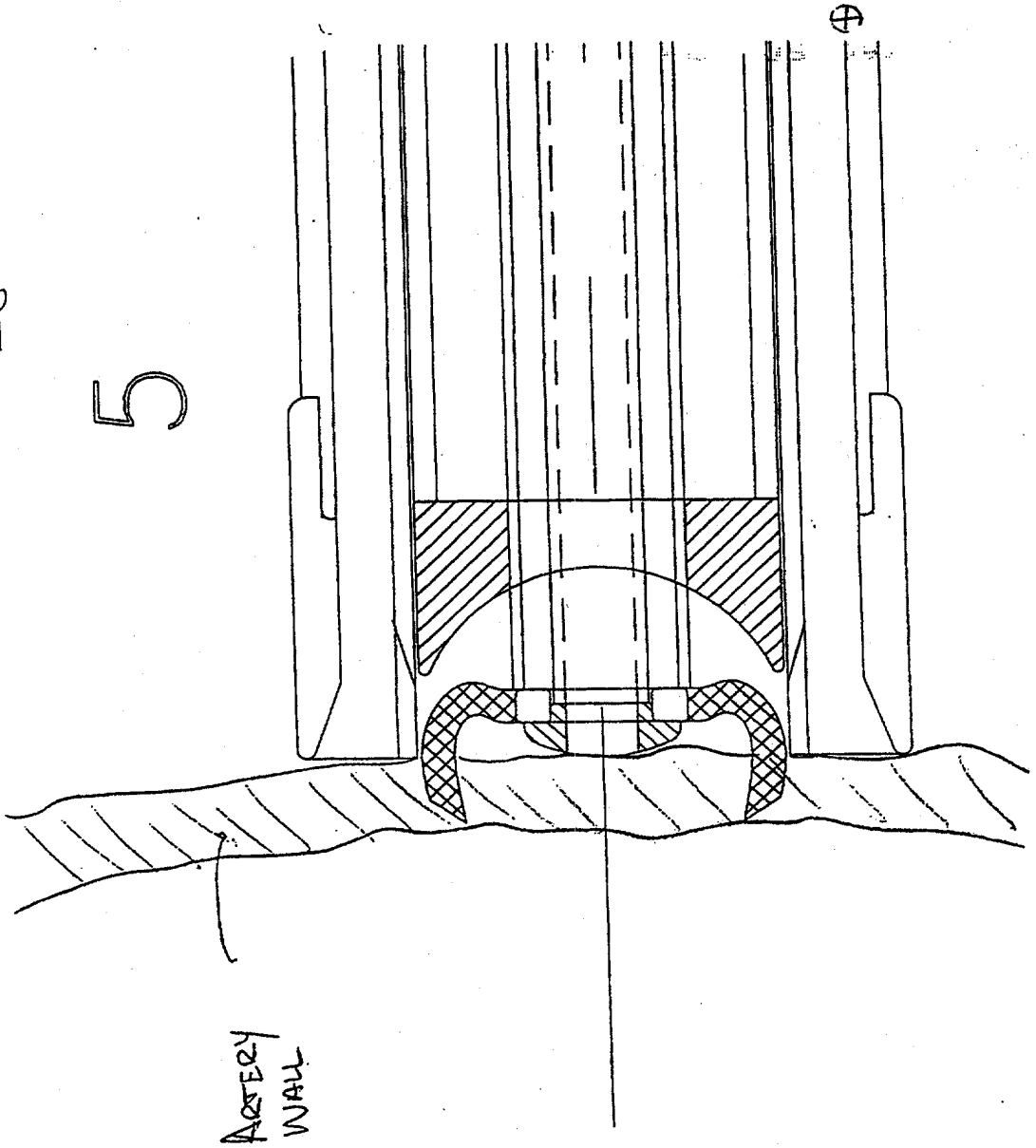
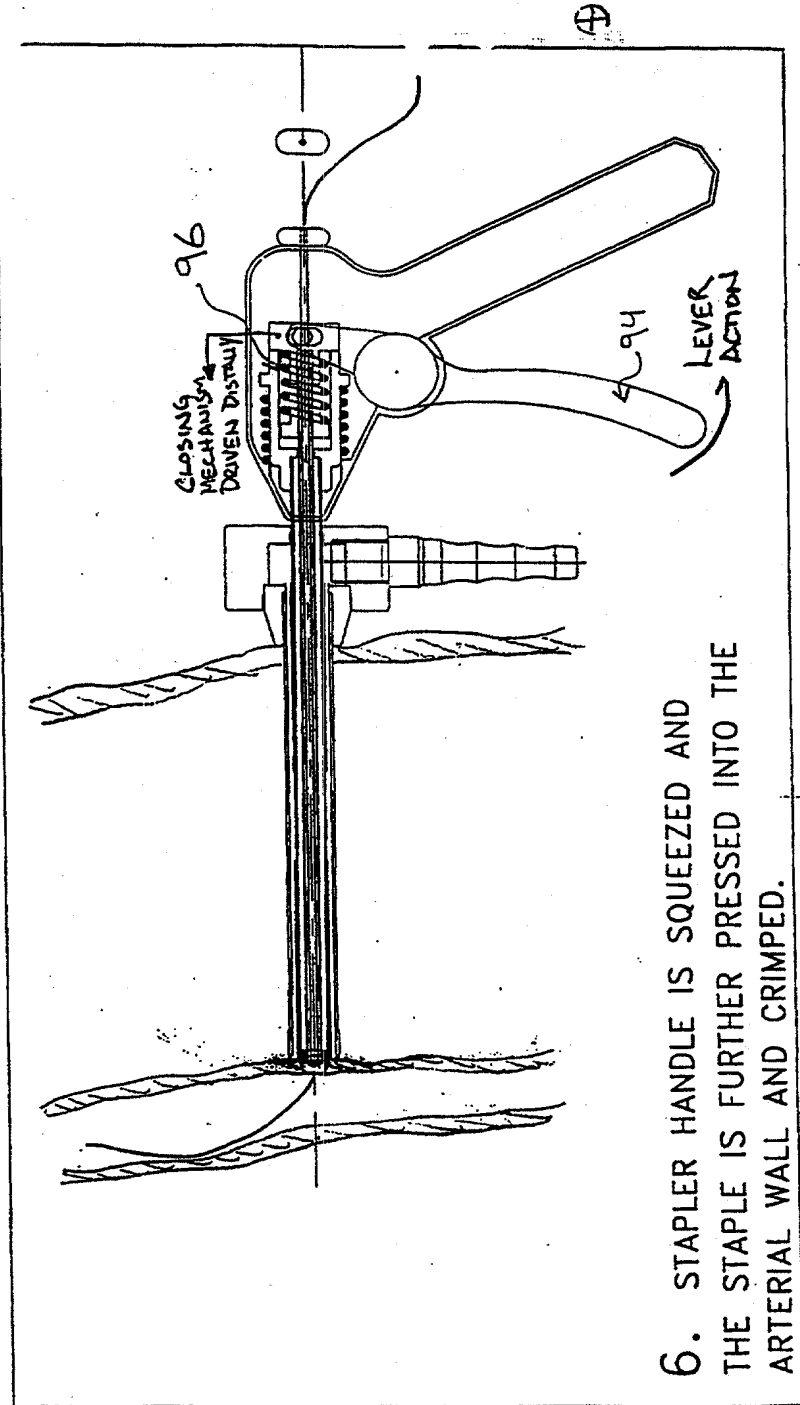

Fig. 13



6. STAPLER HANDLE IS SQUEEZED AND THE STAPLE IS FURTHER PRESSED INTO THE ARTERIAL WALL AND CRIMPED.

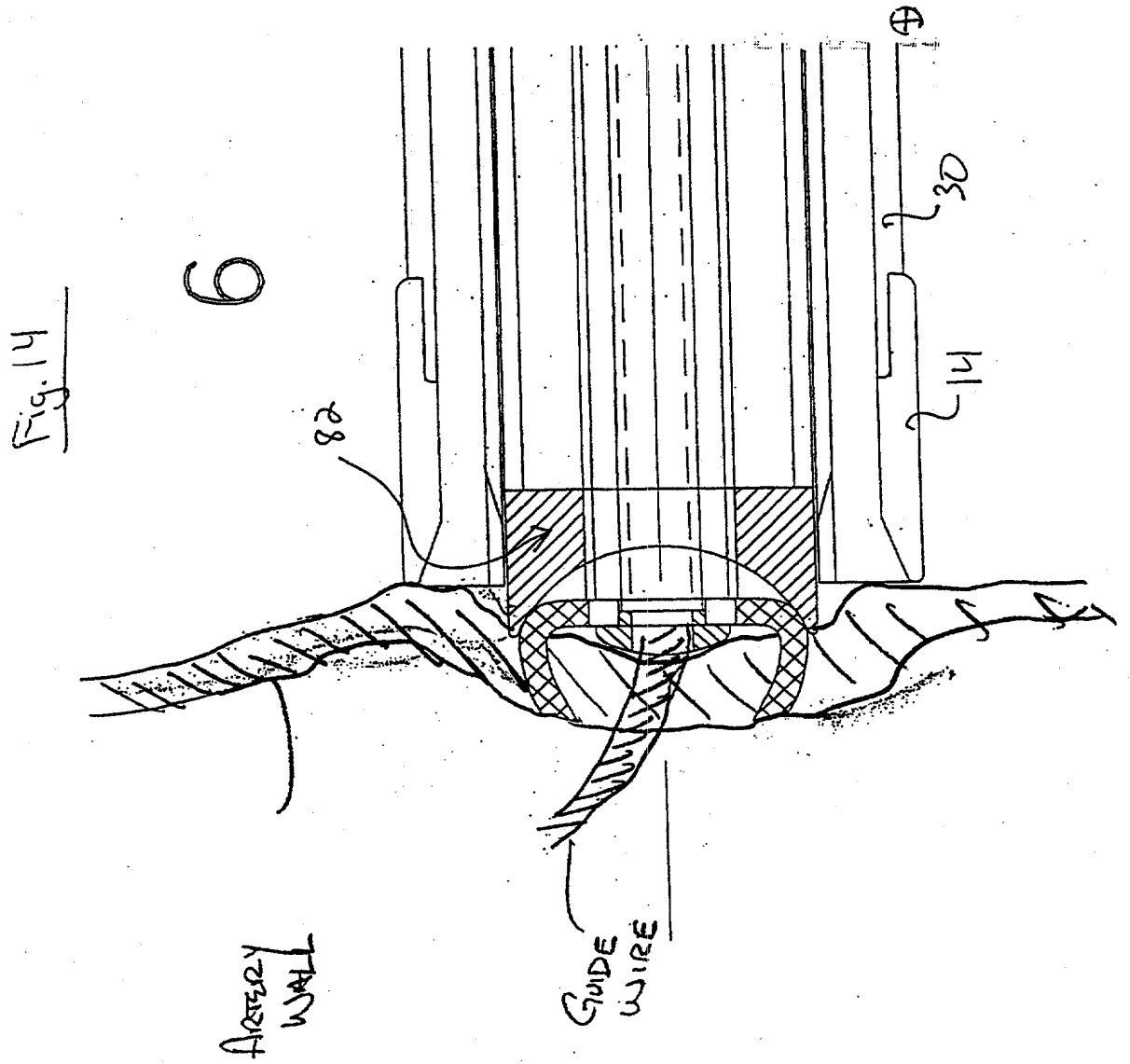
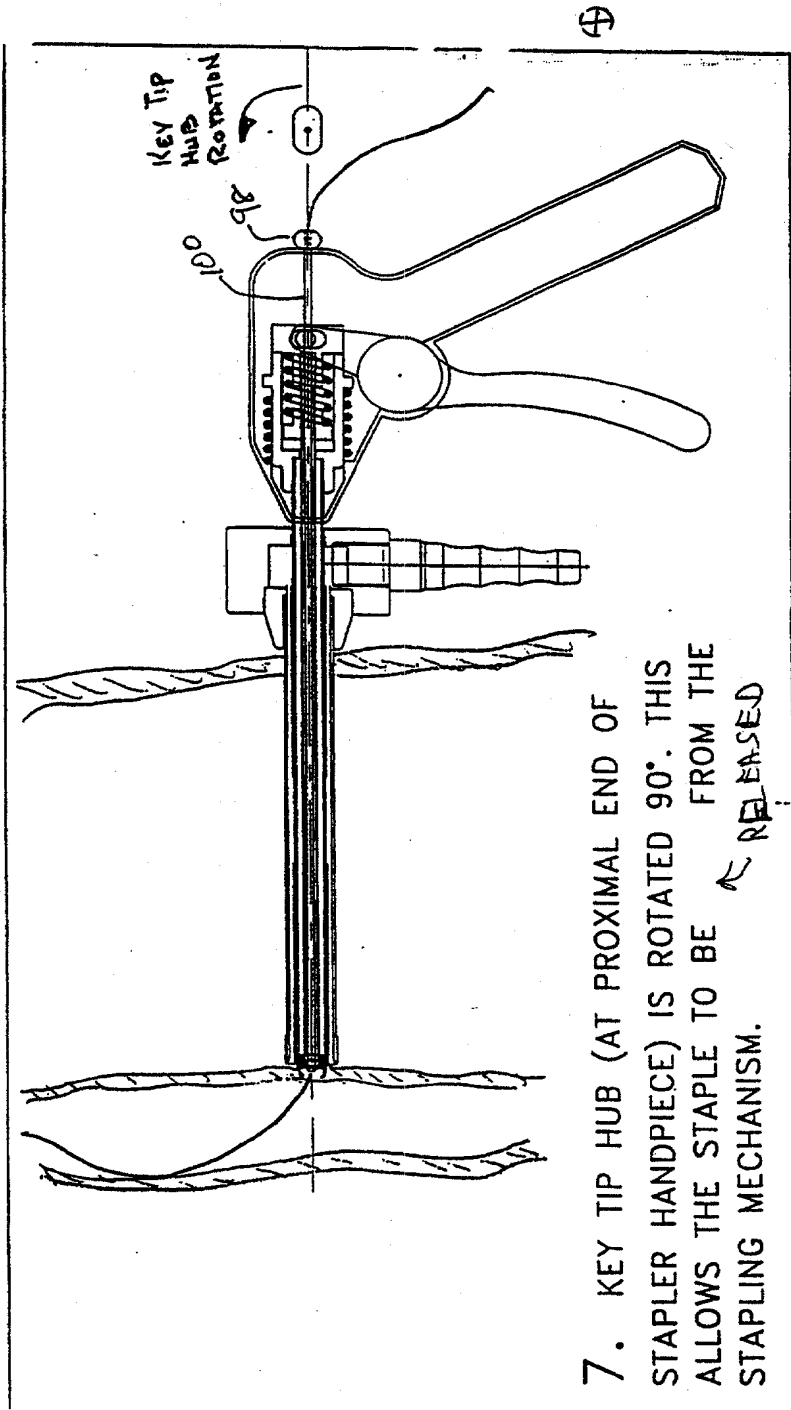
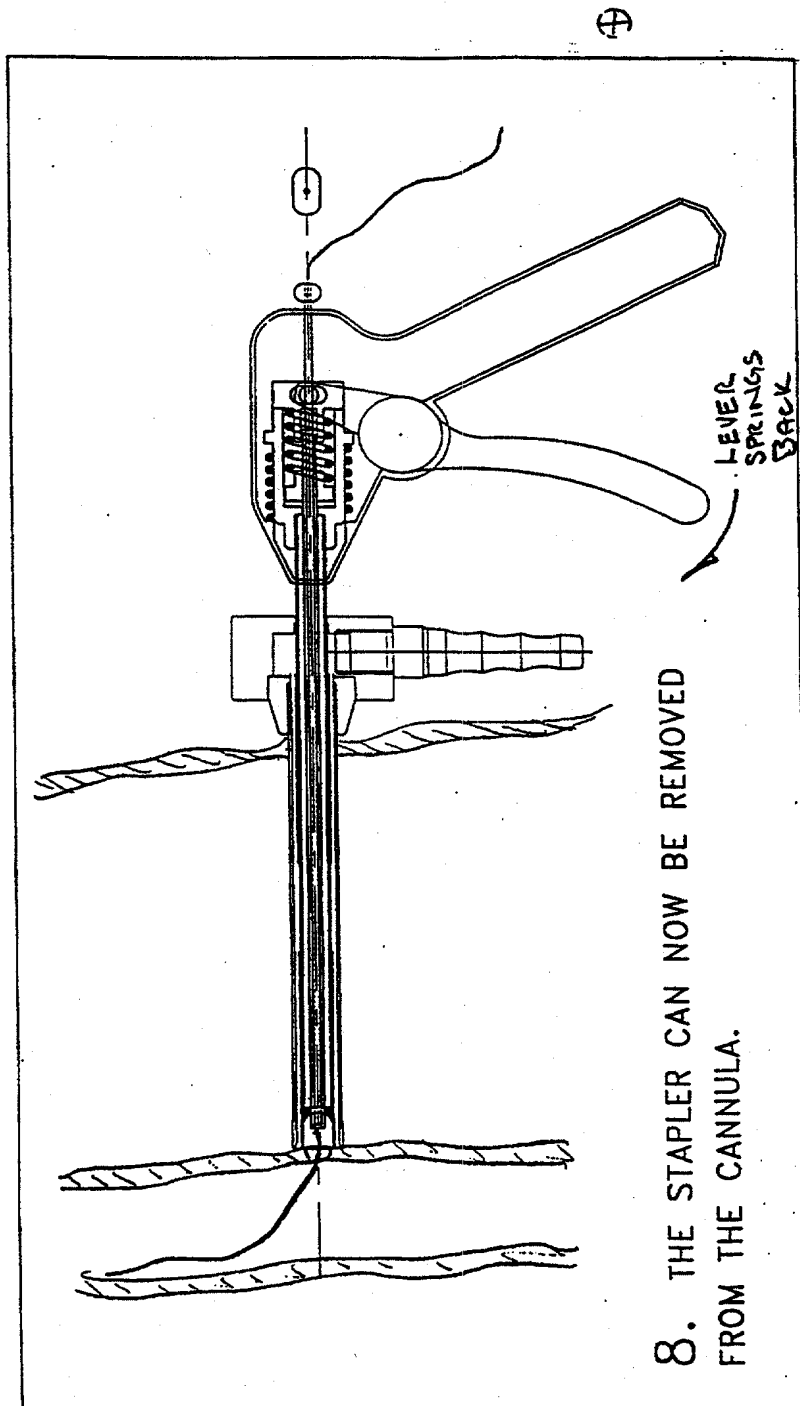

Fig. 15



7. KEY TIP HUB (AT PROXIMAL END OF STAPLER HANDPIECE) IS ROTATED 90°. THIS ALLOWS THE STAPLE TO BE RELEASED FROM THE STAPLING MECHANISM.

Fig. 16



8. THE STAPLER CAN NOW BE REMOVED FROM THE CANNULA.

Fig. 17

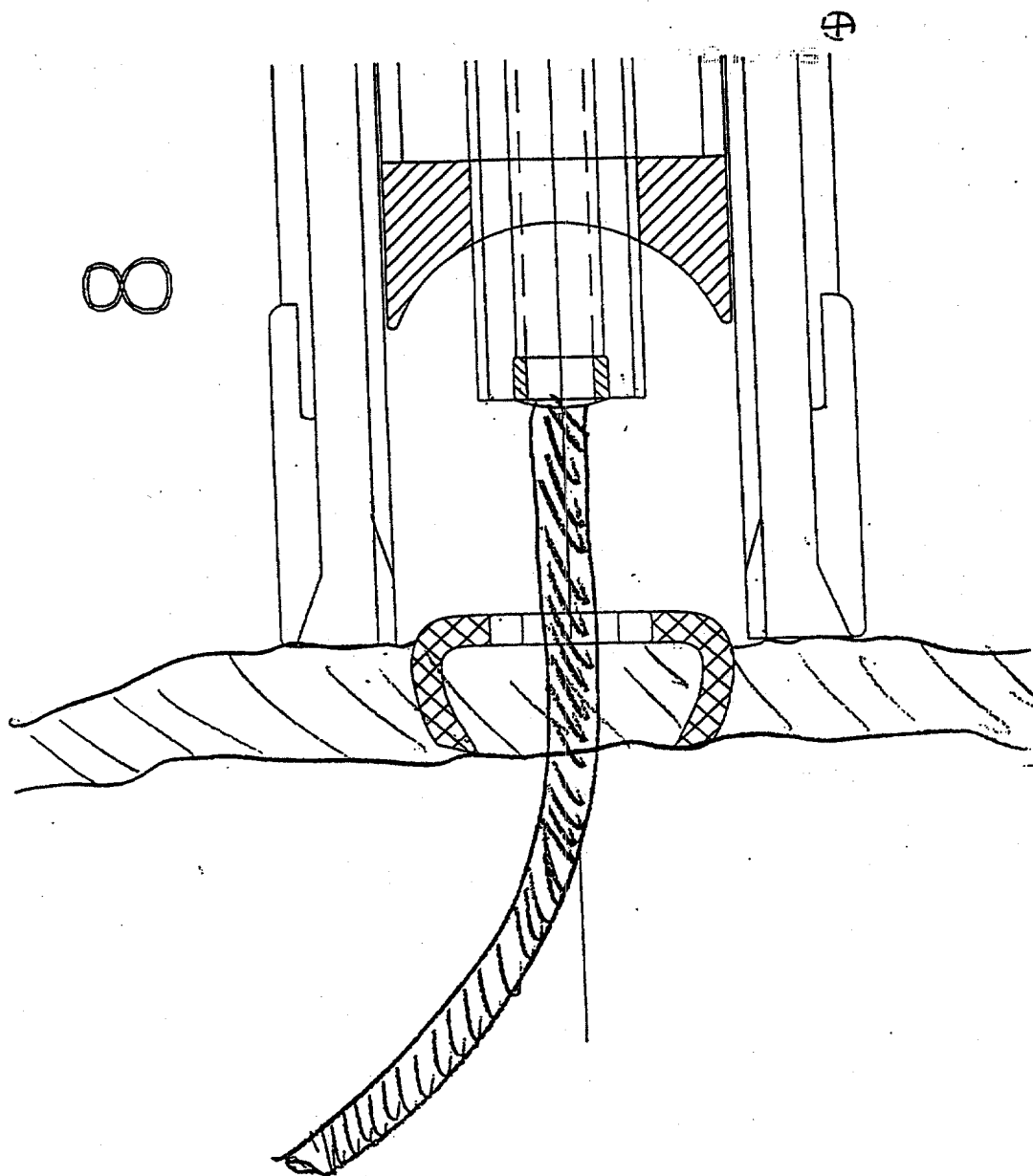
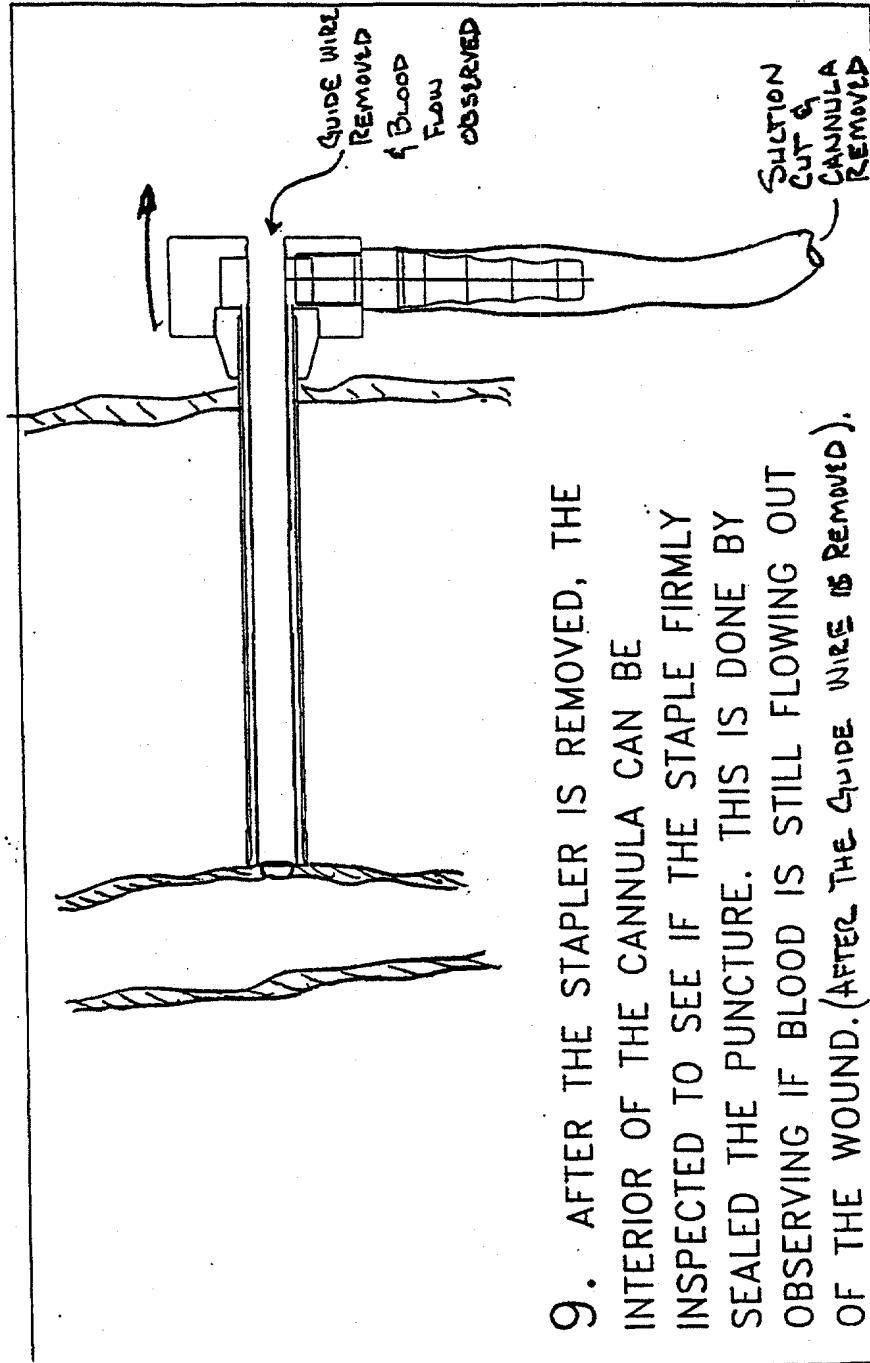

Fig. 18



9. AFTER THE STAPLER IS REMOVED, THE INTERIOR OF THE CANNULA CAN BE INSPECTED TO SEE IF THE STAPLE FIRMLY SEALED THE PUNCTURE. THIS IS DONE BY OBSERVING IF BLOOD IS STILL FLOWING OUT OF THE WOUND. (AFTER THE GUIDE WIRE IS REMOVED).

Fig. 19
9.

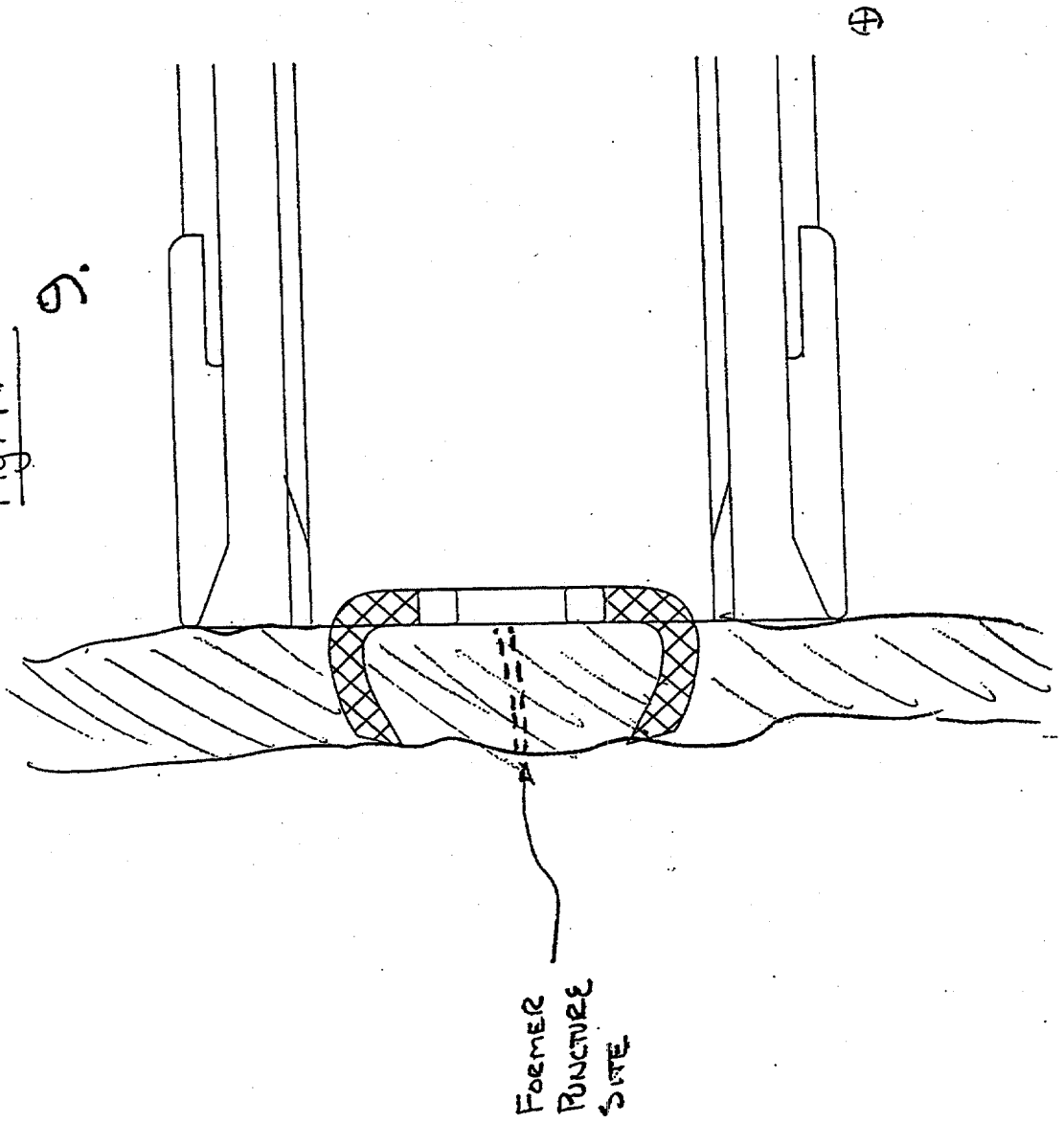

Fig. 20

Dilatator surrounding cannula

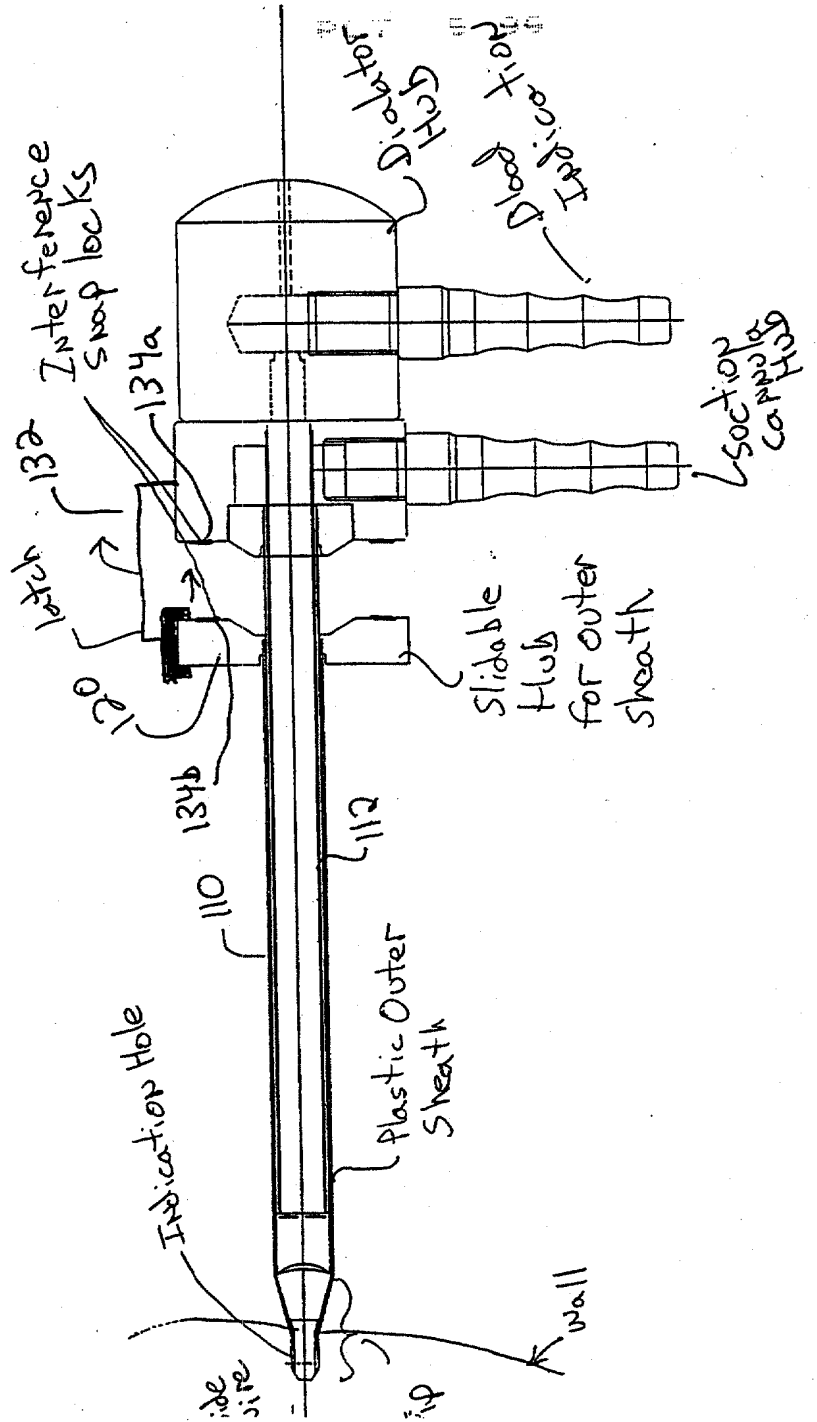

Fig. 21

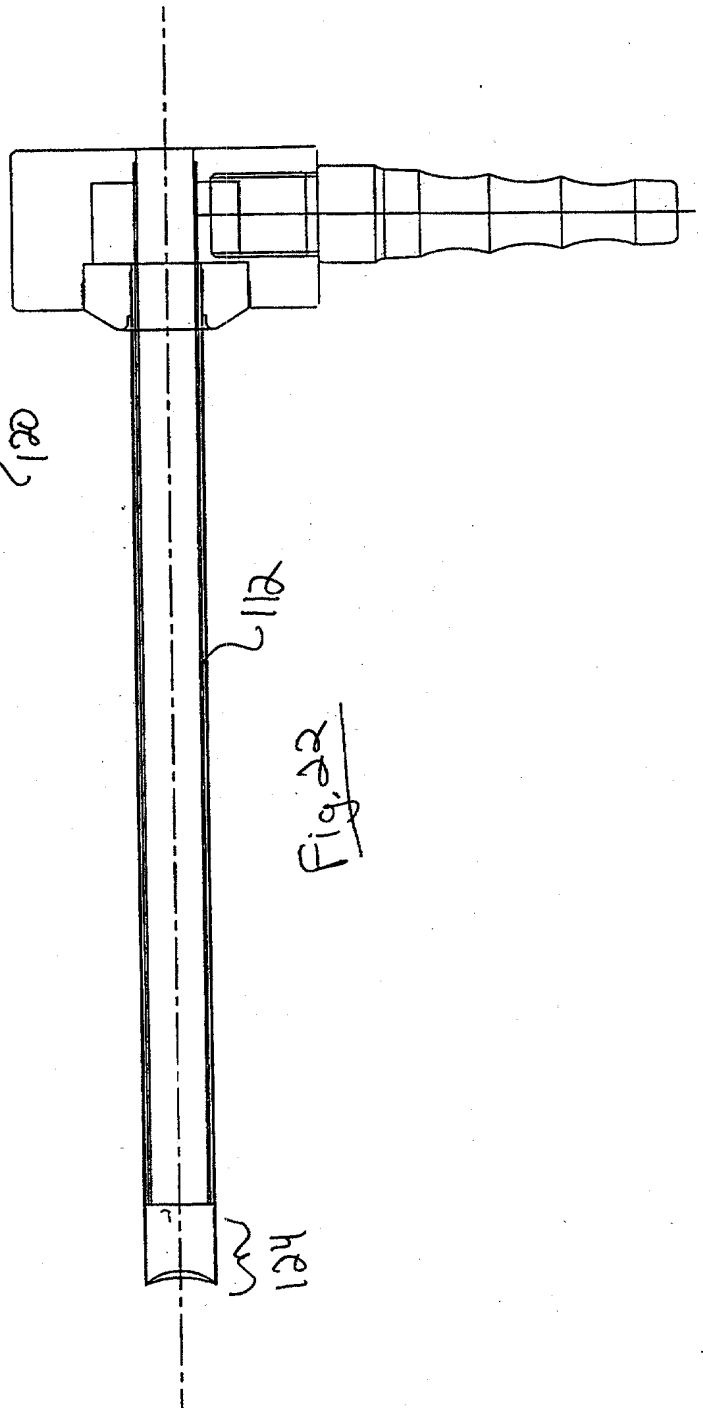
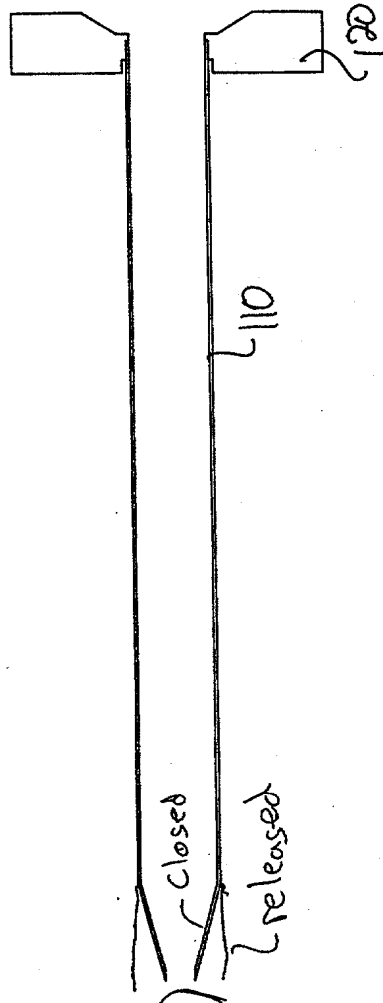
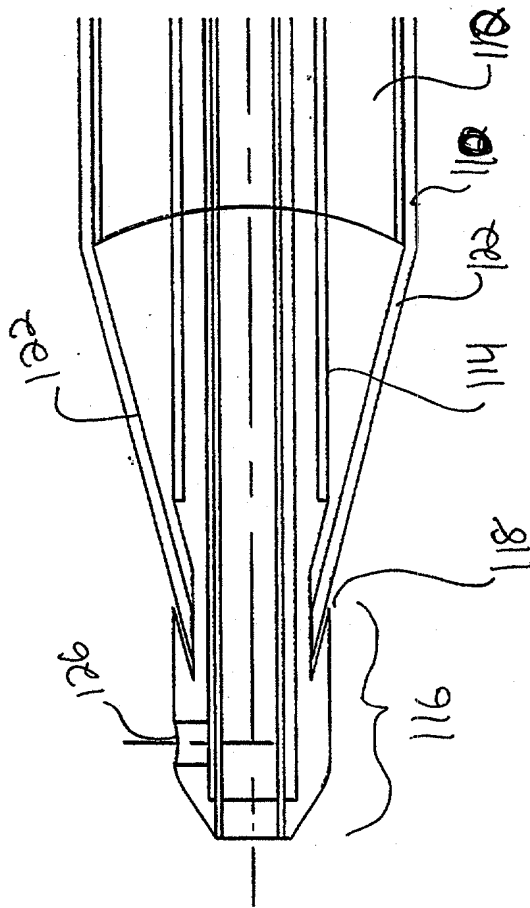

Fig. 22

Fig. 23



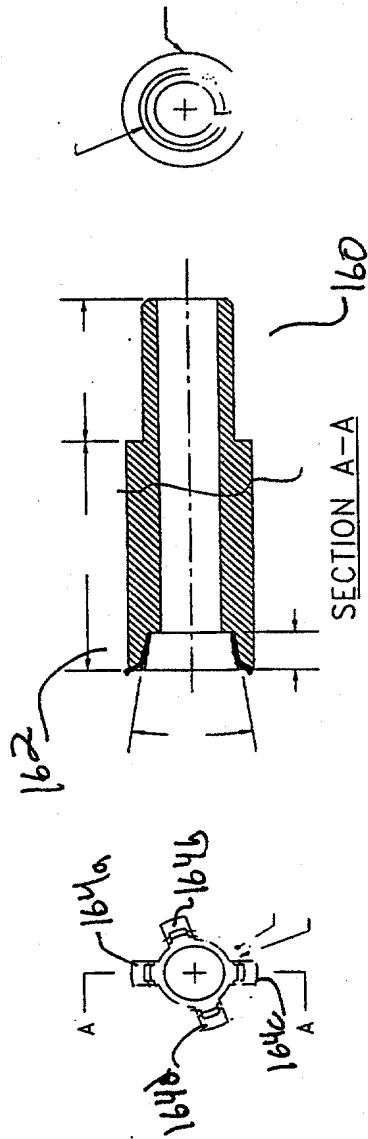

Figure 24A

Figure 24B

Figure 25B

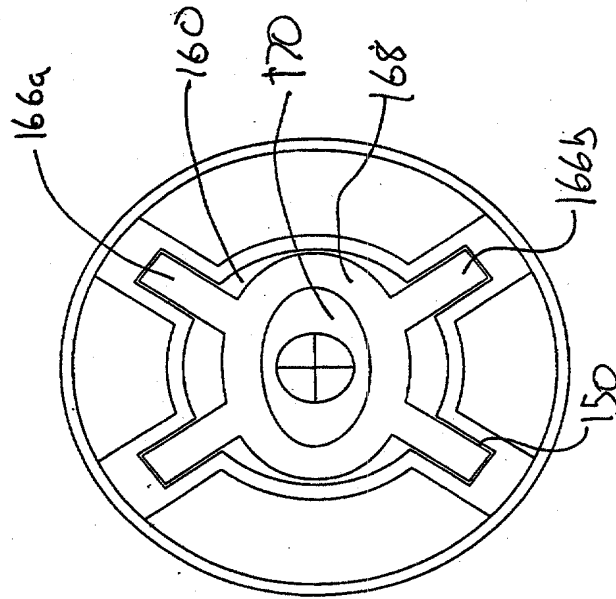

Figure 25A

